

Get the MacDonald Advantage

Injection-molded body is ultra-durable and weighs 1/3 less than metal

Dual hinged lids

Compatible with all standard front-load collection systems

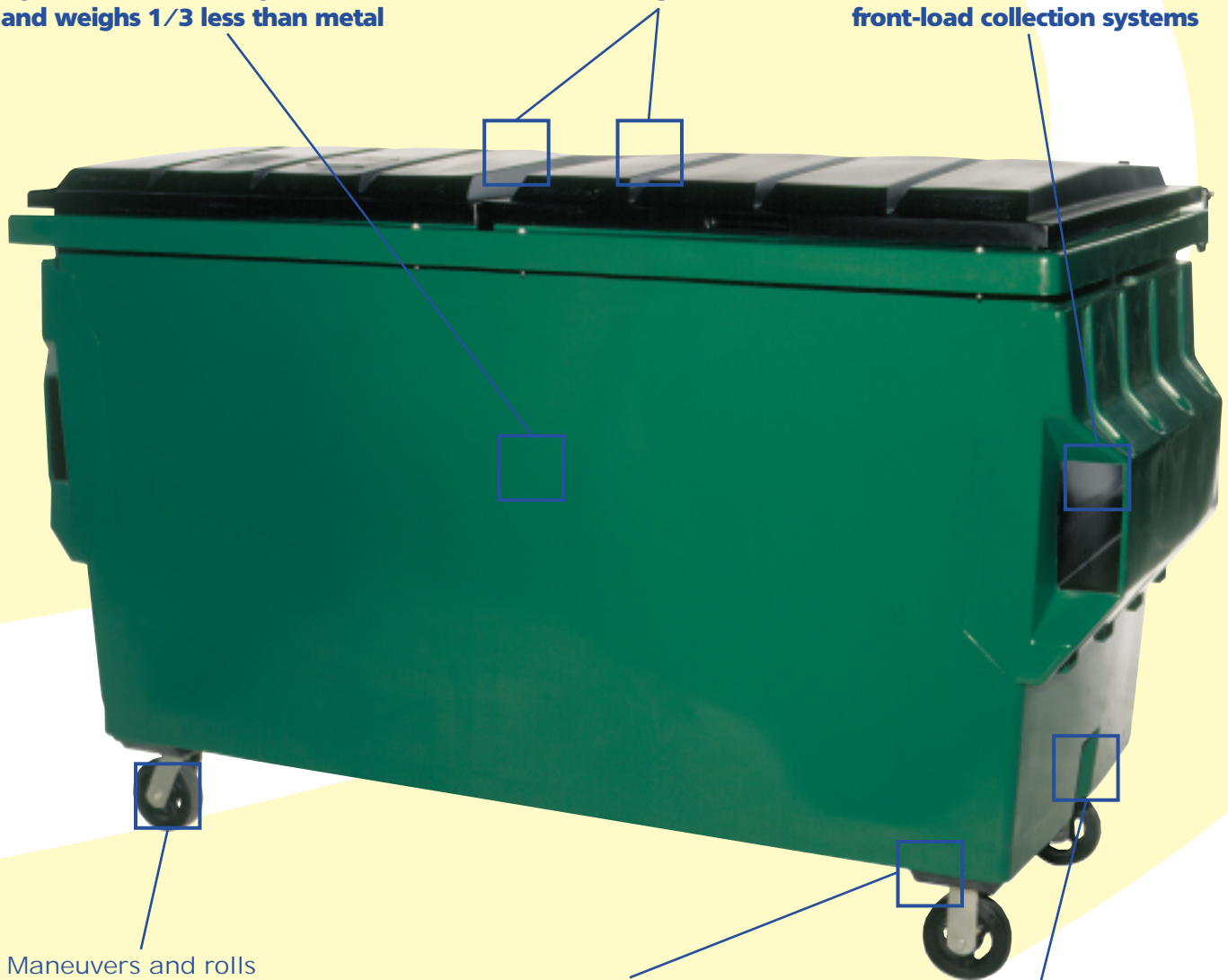

Maneuvers and rolls quietly and easily

Reinforced wheel assembly skid plate for durability and added life

Tough body with drain plug is ideal for wet waste and in-plant applications

It's the MacDonald 1.5m³ Mobile Garbage Bin. With its endurance-engineered, injection-molded body, it's the only structurally uniform 1.5m³ container in the industry. Its uniquely durable design withstands years of harsh weather and use, so it's perfect for outdoor or indoor applications. At MacDonald's, we don't make garbage—we help you collect it.

MacDonald Industries Ltd
186 Stoddard Rd
Mt Roskill
AUCKLAND
Ph 09 620 4059
Fax 09 629 2464
www.macdonaldindustries.co.nz

MacDonald MGB Features



Reinforced castor and floor design for long-life durability

Durable

- Reinforced top rim for extra durability
- Does not crack, dent, rust or corrode in salt air environments
- Never needs painting
- Steel-sleeved side fork pockets are fitted into a corrosion-resistant shroud
- Designed to withstand extreme temperatures and long-term sun exposure
- Sturdy top drip edge keeps rain and insects out

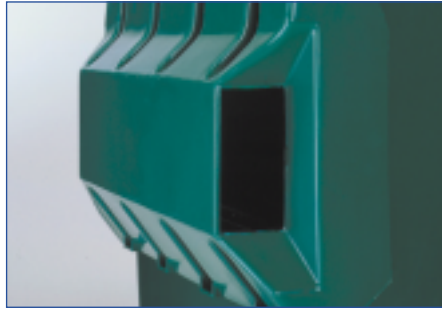

Steel-sleeved side fork pockets enclosed in a rust-resistant shroud

Lightweight, High-Capacity Design

- 1.5m³ capacity—500kgs.
- Weighs 1/3 less than metal containers of same size
- Maneuverability and mobility mean fewer work-related injuries

Easy to Use and Customize

- Drain plug for easy cleaning and drainage
- Impervious to most household chemicals
- Large imprint areas for custom graphics on front and back
- Compatible with all standard front-load collection systems
- Easy to clean



Rustproof drain plug for easy cleaning

Lid and Wheels

- Dual-hinged lid keeps animals out, refuse and odours in
- Self-opening lids for hassle-free dumping
- Resin-reinforced wheel assembly skid plate for extra durability and easy maintenance
- 6" casters for quiet operation
- Container delivered with wheels and lid attached

Specs

Colors: Green, Blue and Brown

Material: Prime grade high density polyethylene

Imprinting: Production date permanently molded on front upper rim. Self-adhesive reflective side lights on all four corners for easy identification

Accessories/Lid Options: Variety of options & accessories available. Call for specific information

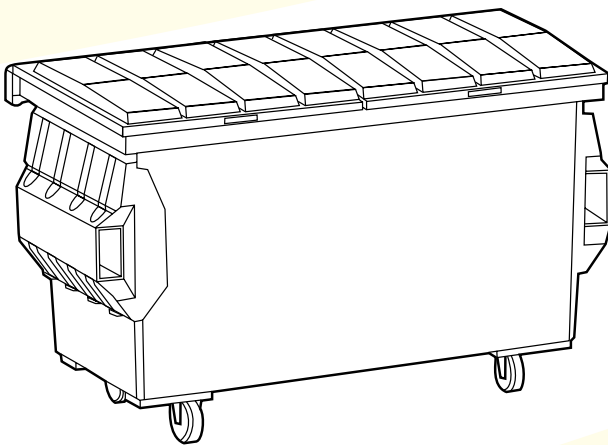

Width	2070mm
Depth	1072mm
Height	990mm
Capacity	500kgs
Assembled Weight	122kgs

Specifications subject to change without notice.

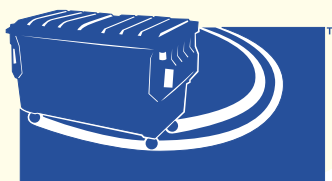

MacDonald Industries Ltd
 186 Stoddard Rd
 Mt Roskill
 AUCKLAND
 Ph 09 620 4059
 Fax 09 629 2464
www.macdonaldindustries.co.nz